

插针数 Contacts	料号 Order No.	产品代号 Part Code	电缆直径(D) Cable outlet	重量 Weight
5	-	M12-MC05A-CCT/R-PG9-D6-SH	4-6mm	-g
	-	M12-MC05A-CCT/R-PG9-D8-SH	6-8mm	-g
	-	M12-MC05A-CCT/R-M16-D6-SH	4-6mm	-g
	1630057102001	M12-MC05A-CCT/R-M16-D8-SH	6-8mm	43.6g

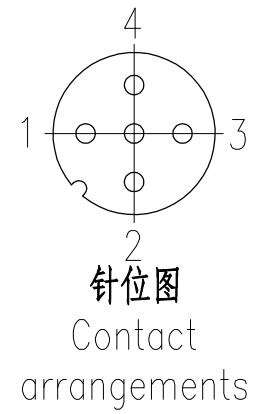
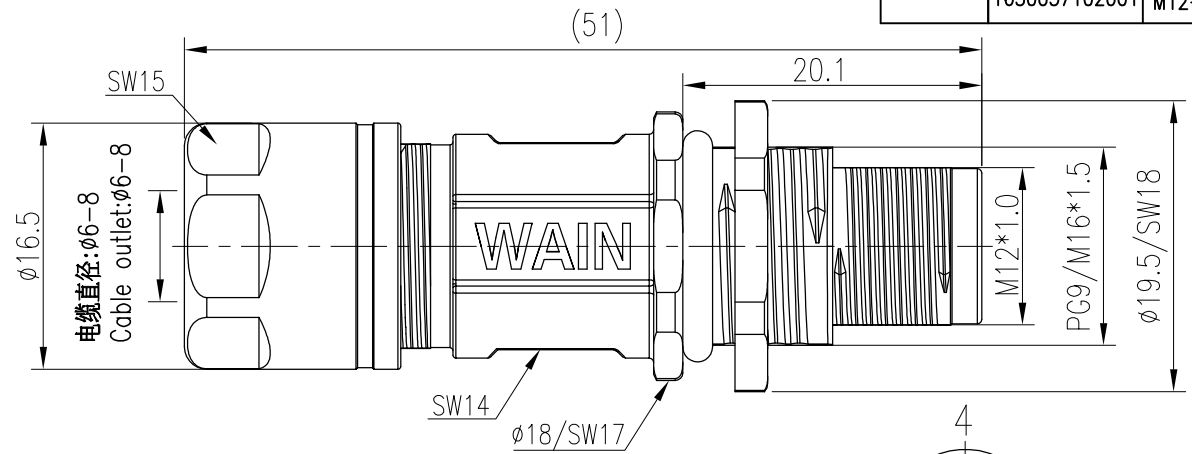
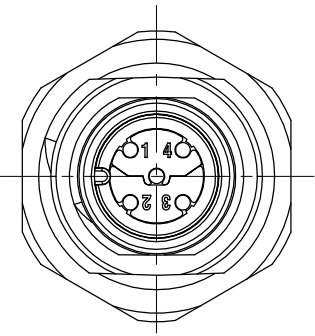

面板安装尺寸 Panel Cut-out										
通孔安装 With bore hole	螺纹安装 With thread to screw in									
比例/scale 1:1	比例/scale 1:1									
	<table border="1"> <thead> <tr> <th></th> <th>A</th> <th>B</th> </tr> </thead> <tbody> <tr> <td>PG9</td> <td>PG9</td> <td>φ15.3</td> </tr> <tr> <td>M16x1.5</td> <td>M16x1.5</td> <td>φ16.1</td> </tr> </tbody> </table>		A	B	PG9	PG9	φ15.3	M16x1.5	M16x1.5	φ16.1
	A	B								
PG9	PG9	φ15.3								
M16x1.5	M16x1.5	φ16.1								

技术参数:
 - 产品系列: M12 A-Code
 - 插针数: 5
 - 额定电流(40℃): 4A
 - 额定电压: 125V
 - 额定脉冲电压: 1500V
 - 污染等级: 3
 - 接触电阻: ≤10mΩ
 - 防护等级: IP67
 - 插拔次数: >100
 - 温度范围: -40℃...+85℃
 - 绝缘阻抗: >100MΩ
 - 接线方式: 冷压压接
 - 线径范围: 0.25-0.82mm² (18-26AWG)
 - 电缆直径: 6-8mm

材料特性:
 - 锁紧螺帽: 金属
 - 插针材料: 铜合金
 插针表面处理: 镀金
 - 外壳材料: 锌合金
 - 绝缘材料: PA

符合标准: IEC 61076-2-101

Technical specification:
 - Series: M12 A-Code
 - Number of contacts: 5
 - Rated current(40℃): 4A
 - Rated voltage: 125V
 - Rated impulse voltage: 1500V
 - Pollution degree: 3
 - Contact resistance: ≤10mΩ
 - Degree of protection: IP67
 - Mating cycles: >100
 - Temperature range: -40℃ - +85℃
 - Insulation resistance: >100MΩ
 - Termination method: Crimp termination
 - Wire gauge: 0.25-0.82mm² (18-26AWG)
 - Cable Outlet: 6-8mm

Material properties:
 - Material of locking system: Metal
 - Material of contact: copper alloy
 Contact plating: Au
 - Material of housing: Zinc die-cast
 - Material of Insert: PA

Standards: IEC 61076-2-101

标记 Mark		数量 Number	变更描述/Description		姓名/Name	日期/Date	表面处理 Finish				图号 Drawing No.
绘图 Drawn		L CHEN	09.10.2022		-		-				-
审核 Checked		ZQ XU	09.10.2022		-		-				产品代号 Part Code
工艺 Process		-	-		-		-				详见上表
							材料 Material				产品料号 Part No.
							比例 Scale				-
							版本 REV.				产品名称 Part Name
							重量 Weight				-
							数量 Qty.				-
							批准 Approved				-
					HQ ZHANG 09.10.2022		All Dimensions in mm Original Size DIN A 4				厦门唯恩电气有限公司 YAMEN WAIN ELECTRICAL CO., LTD.