

- 技术参数:**
- 产品系列: M12 A-Code
 - 插针数: 4、5、8
 - 额定电流(40℃): 4A
 - 额定电压: 250V(4-pole)、125V(5-pole)
 - 额定脉冲电压: 2500V(4-pole)、1500V(5-pole)
 - 污染等级: 3
 - 接触电阻: $\leq 10m\Omega$
 - 绝缘电阻: $\geq 100M\Omega$
 - 锁紧方式: 螺纹式M12*1
 - 连接方式: 焊接, 线规: 最大0.25mm² (AWG24)
 - 防护等级: IP67
 - 插拔次数: ≥ 100
 - 温度范围: -40℃ ... +85℃
 - 外壳材料: 铸锌镍
 - 插体材料: PA
 - 插针材料: 铜合金
 - 插针电镀材料: 金

- Technical specification:**
- Series: M12 A-Code
 - Number of contacts: 4, 5, 8
 - Rated current (40℃): 4A
 - Rated voltage: 250V(4-pole)、125V(5-pole)
 - Rated impulse voltage: 2500V(4-pole)、1500V(5-pole)
 - Pollution degree: 3
 - Contact resistance: $\leq 10m\Omega$
 - Insulation resistance: $\geq 100M\Omega$
 - Connector locking system: screw M12*1
 - Terminal: solder, wire gauge: max.0.25mm²(AWG24)
 - Degree of protection: IP67
 - Mating cycles: ≥ 100
 - Temperature range: -40℃ ... +85℃
 - Material of housing: Zinc diecasting nickel plated
 - Material of insert: PA
 - Material of contact: copper alloy
 - Contact plating: Au

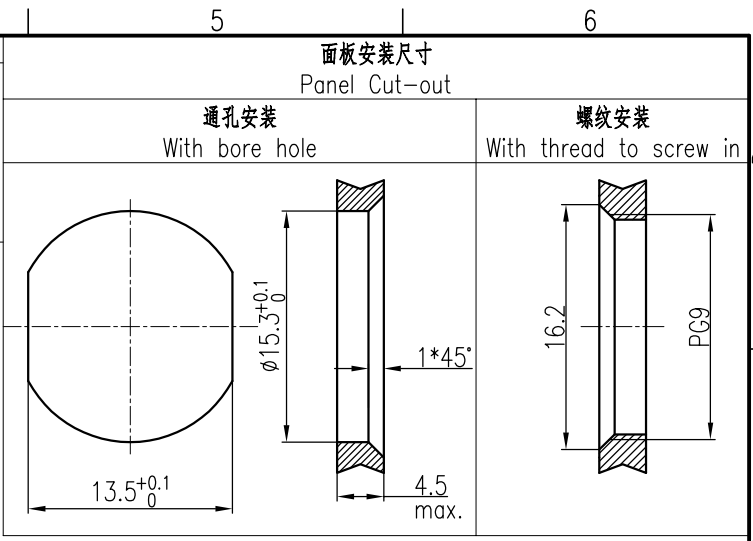
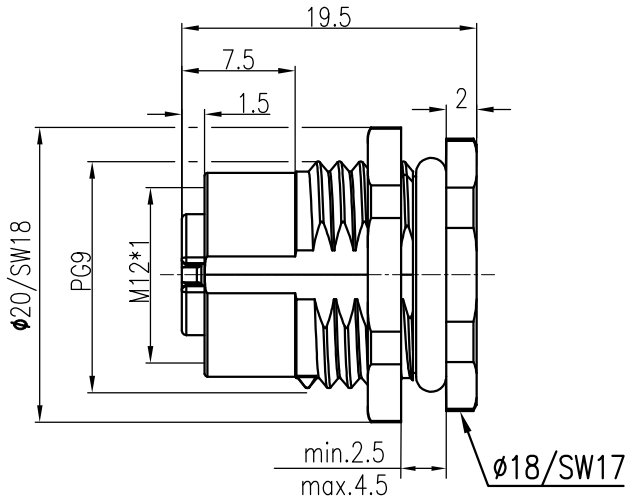
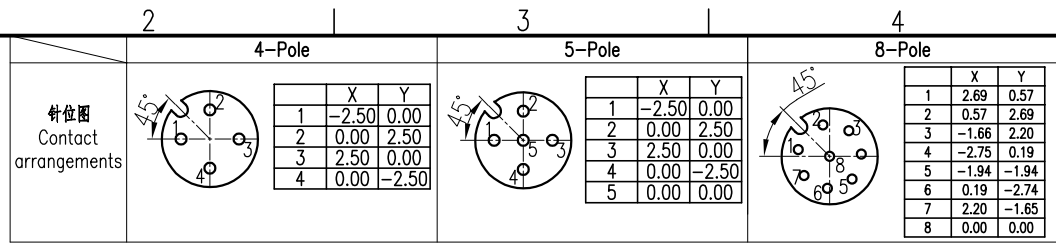

插针数 Contacts	产品料号 Cable outlet	型号 Part Code	重量 Weight
4	1630043231011	M12-F04A-BKR-PG9-C	10.8 g
5	1630053231011	M12-F05A-BKR-PG9-C	10.8 g
8	1630083231011	M12-F08A-BKR-PG9-C	10.8 g

表面处理 Finish	-			图号 Drawing No.	-		
材料 Material	-			产品代号 Part Code	M12-FXX-BKR-PG9-C		
比例 Scale	2:1	版本 REV.	V1.1	产品料号 Part No.	-		
重量 Weight	-	数量 Qty.	-	产品名称 Part Name	-		
工艺 Process	-	批准 Approved	YY LUO	厦门唯恩电气有限公司 XIAMEN WAIN ELECTRICAL CO.LTD			
标记 Mark	处数 Number	变更描述/Description	签名 Signature	日期 Date	姓名/Name	日期/Date	日期/Date
绘图 Drawn	HQ ZHANG	17.04.2014	标准化 Stand.	-	-	-	-
审核 Checked	ZM LIN	17.04.2014	-	-	-	-	-