

日期/Date

档案员
Filing Clerk

1

2

3

4

5

6

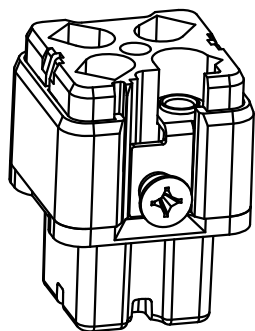
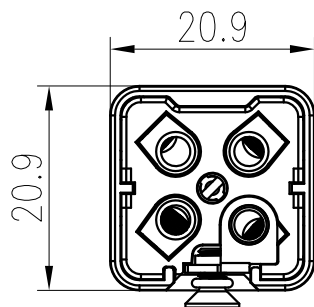
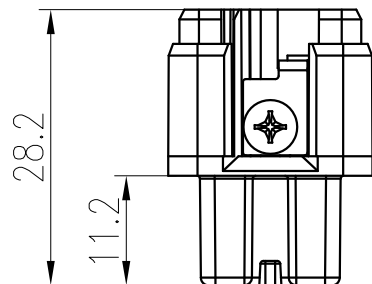

技术参数:

插芯:

- 插针数: 3+PE
 - 额定电流: 10A
 - 相对地额定电压: 230V
 - 相间额定电压: 400V
 - 额定脉冲电压: 4kV
 - 污染等级: 3
 - 依据UL/CSA的额定电压: 600V
 - 绝缘阻抗: $\geq 10^{10}\Omega$
 - 材料: 聚碳酸酯
 - 颜色: RAL 7032 (浅灰色)
 - 温度范围: $-40^{\circ}\text{C} - +125^{\circ}\text{C}$
 - 依据UL 94的阻燃等级: V0
 - 可插拔次数: ≥ 500
- 插针:
- 接线方式: 螺钉连接
 - 材料: 铜合金
 - 表面处理: 镀银
 - 接触电阻: $\leq 1\text{m}\Omega$
 - 线径范围: $0.75-2.5\text{mm}^2(18-14 \text{ AWG})$
 - 拧紧/检测力矩: $0.25\text{N}\cdot\text{m}$

Technical specification:

Inserts:

- No. of contact: 3+PE
 - Rated current: 10A
 - Rated voltage-ground: 230V
 - Rated voltage-conductor: 400V
 - Rated impulse voltage: 4kV
 - Pollution degree: 3
 - Rated voltage acc.to UL/CSA: 600V
 - Insulation resistance: $\geq 10^{10}\Omega$
 - Material: polycarbonate
 - Colour: RAL 7032(light grey)
 - Temperature range: $-40^{\circ}\text{C} - +125^{\circ}\text{C}$
 - Flammability acc.to UL 94: V0
 - Mating cycles: ≥ 500
- Contacts:
- Terminal: screw terminal
 - Material: copper alloy
 - Surface: hard-silver plated
 - Contact resistance: $\leq 1\text{m}\Omega$
 - Wire gauge: $0.75-2.5\text{mm}^2(18-14 \text{ AWG})$
 - Tightening/Test torque: $0.25\text{N}\cdot\text{m}$

						表面处理 Finish	-			图号 Drawing No.	-
						材料 Material	-			产品代号 Part Code	HA-003-F-V2
标记 Mark	处数 Number	变更描述/Description			签名 Signature	日期 Date				产品料号 Part No.	1210030210505
	姓名/Name	日期/Date		姓名/Name	日期/Date	比例 Scale	版本 REV.	重量 Weight	数量 Qty.	产品名称 Part Name	HA-003-F-V2,成品
绘图 Drawn	JY CAI	28.03.2021	标准化 Stand.	-	-	3:4	V1.0	15.8g	-		
审核 Checked	HZ LAN	28.03.2021									
工艺 Process	-	-	批准 Approved	HQ ZHANG	28.03.2021			All Dimensions in mm Original Size DIN A 4		厦门唯恩电气有限公司 XIAMEN WAIN ELECTRICAL CO.,LTD	

1

2

3

4

5

6