

日期/Date		档案员 Filing Clerk		1		2			3		4		5						6
产品代号 Part Code	产品料号 Part NO.	重量/Weight		线径/Wire Gauge		d	D	剥线长度 Stripping Length	标识 Identification	标识图 Identification No.	No.	No.1	No.2	No.3	No.4	No.5	No.6		
		g	mm <sup>2</sup>	AWG															
CEGFH-0.37G	1010192200309	1.6	0.14-0.37	26-22	0.90	1.8	7.5	no groove	No.1	标示图 Marked Graph									
CEGFH-0.5G	1010192200409	1.7	0.5	20	1.15	2.6	7.5	no groove	No.1										
CEGFH-0.75G	1010192200609	1.7	0.75	18	1.30	2.6	7.5	1 groove	No.2										
CEGFH-1.0G	1010192200809	1.7	1.0	18	1.45	2.6	7.5	1 groove	No.3										
CEGFH-1.5G	1010192200909	1.8	1.5	16	1.75	3.0	7.5	2 groove	No.4										
CEGFH-2.5G	1010192201009	1.8	2.5	14	2.25	3.5	7.5	3 groove	No.5										
CEGFH-3.0G	1010192201109	1.7	3.0	12	2.55	3.7	7.5	wide groove	No.6										
CEGFH-4.0G	1010192201209	1.7	4.0	12	2.85	3.9	7.5	no groove	No.1										

技术参数:

- 材料: 铜合金
- 表面处理: 镀金, 导电润滑脂
- 额定电流: 16A
- 接触电阻:  $\leq 1\text{m}\Omega$
- 工作温度范围:  $-40^{\circ}\text{C} \dots +125^{\circ}\text{C}$
- 线径范围:  $0.14-4.0\text{mm}^2$  (26-12 AWG)
- 可插拔次数:  $\geq 5000$

Technical specification:

- Material: copper alloy, conductive grease
- Surface: hard-gold plated
- Rated current: 16A
- Contact resistance:  $\leq 1\text{m}\Omega$
- Limiting temperatures:  $-40^{\circ}\text{C} \dots +125^{\circ}\text{C}$
- Wire gauge:  $0.14-4.0\text{mm}^2$  (26-12 AWG)
- Mating cycles:  $\geq 5000$

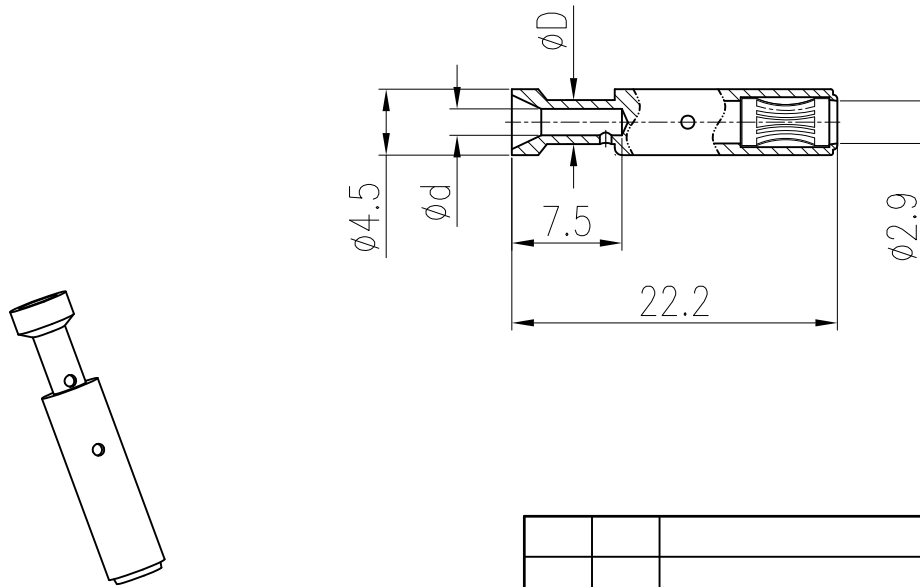

						表面处理 Finish		-		图号 Drawing No.		-	
						材料 Material		-		产品代号 Part Code		CEGFH-XXG	
标记 Mark		处数 Number		变更描述/Description		签名 Signature		日期 Date		产品料号 Part No.		-	
		姓名/Name		日期/Date						产品名称 Part Name		-	
绘图 Drawn		TC CHEN		30.01.2015		标准化 Stand.		-		比例 Scale		-	
审核 Checked		ZM LIN		30.01.2015						版本 REV.		-	
工艺 Process		-		-		批准 Approved		YY LUO		重量 Weight		-	
								30.01.2015		数量 Qty.		-	
										All Dimensions in mm Original Size DIN A 4		厦门唯恩电气有限公司 XIAMEN WAIN ELECTRICAL CO.LTD	