

日期/Date  
Filing Clerk  
送样员

**技术参数:**  
 - 产品系列: M12 X-Code  
 - 插针数: 8  
 - 额定电流(40℃): 0.5A  
 - 额定电压: 50V a.c. 60V d.c.  
 - 额定脉冲电压: 0.8KV  
 - 污染等级: 3  
 - 接触电阻: ≤10mΩ  
 - 绝缘电阻: ≥100MΩ  
 - 锁紧方式: 螺纹式M12\*1  
 - 电缆类型: PUR Cat.6a  
 - 线规: 0.14mm<sup>2</sup> (26AWG)  
 - 防护等级: IP67  
 - 插拔次数: ≥100  
 - 温度范围: -40℃ ... +85℃  
 - 外壳材料: 铸锌镍  
 - 插体材料: PA  
 - 插针材料: 铜合金  
 - 插针电镀材料: 金

**Technical specification:**  
 - Series: M12 X-Code  
 - Number of contacts: 8  
 - Rated current (40℃): 0.5A  
 - Rated voltage: 50V a.c. 60V d.c.  
 - Rated impulse voltage: 0.8KV  
 - Pollution degree: 3  
 - Contact resistance: ≤10mΩ  
 - Insulation resistance: ≥100MΩ  
 - Connector locking system: screw M12\*1  
 - Cable Type: PUR Cat.6a  
 - Wire Spec: 0.14mm<sup>2</sup>(26AWG)  
 - Degree of protection: IP67  
 - Mating cycles: ≥100  
 - Temperature range: -40℃ ... +85℃  
 - Material of housing: Zinc diecasting nickel plated  
 - Material of insert: PA  
 - Material of contact: copper alloy  
 - Contact plating: Au

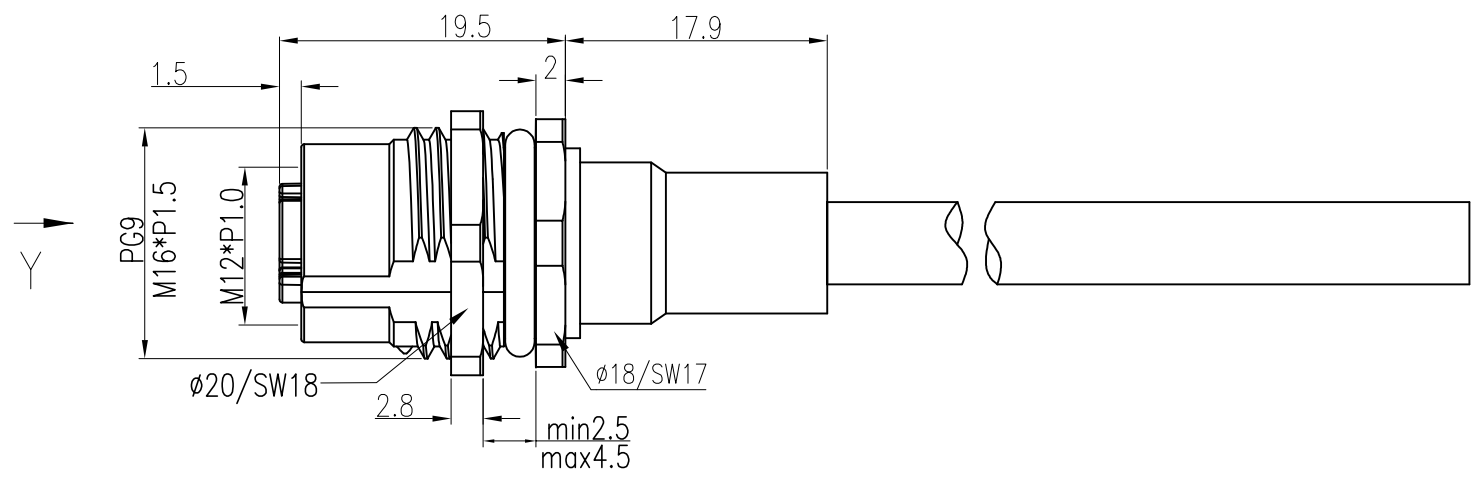
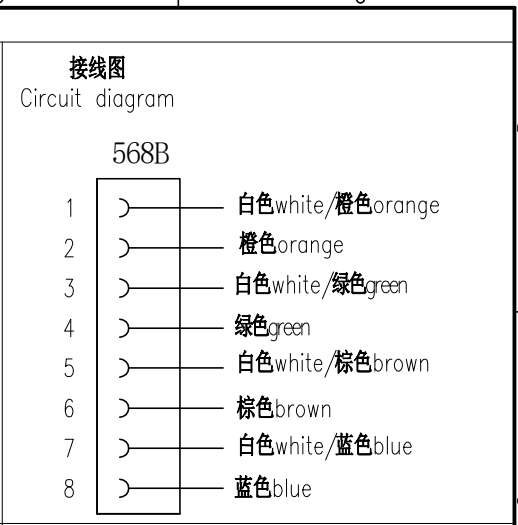
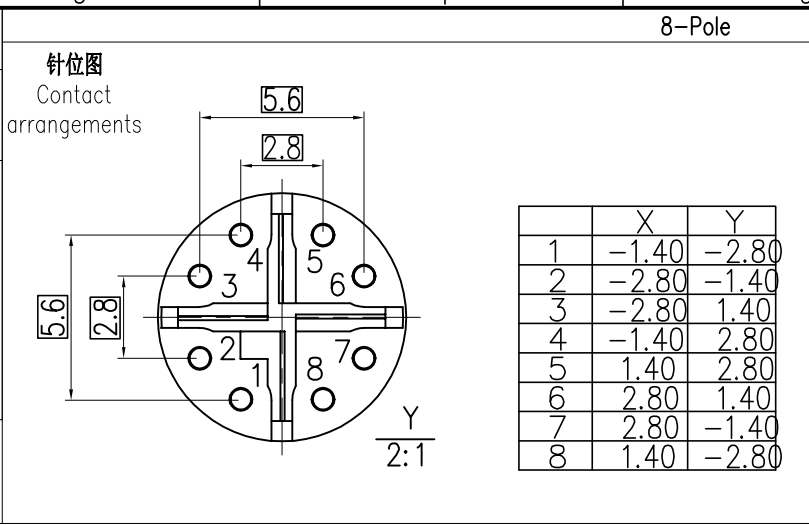
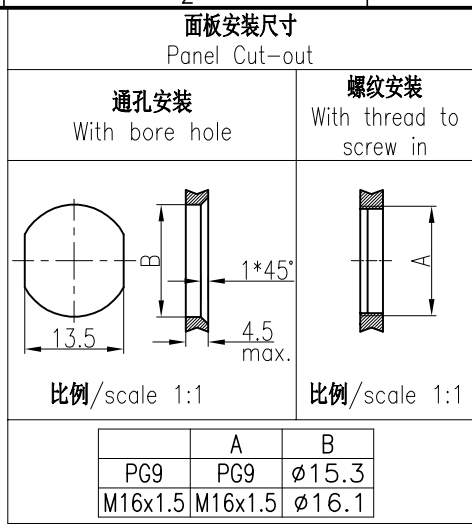

					表面处理 Finish	-				图号 Drawing No.	-	
					材料 Material	-				产品代号 Part Code	M12-F08X-BKR-PG9-Cat.6A	
标记 Mark	处数 Number	变更描述/Description		签名 Signature		日期 Date					产品料号 Part No.	1630083024003
		姓名/Name	日期/Date			比例 Scale	版本 REV.	重量 Weight	数量 Qty.	产品名称 Part Name		-
绘图 Drawn	YP ZHUANG	12.05.2020	标准化 Stand.			2:1	V1.0	-	-			
审核 Checked	ZQ XU	12.05.2020										
工艺 Process	-	-	批准 Approved	HQ ZHANG	12.05.2020							
							All Dimensions in mm Original Size DIN A 4		<b>厦门唯恩电气有限公司</b> XIAMEN WAIN ELECTRICAL CO.LTD			